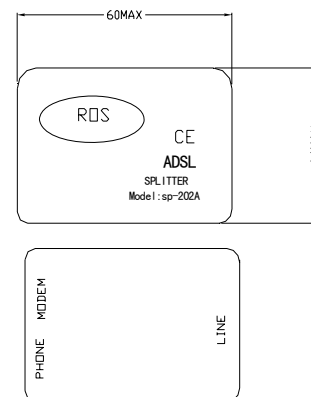
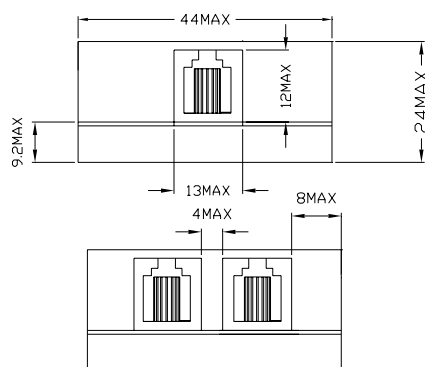
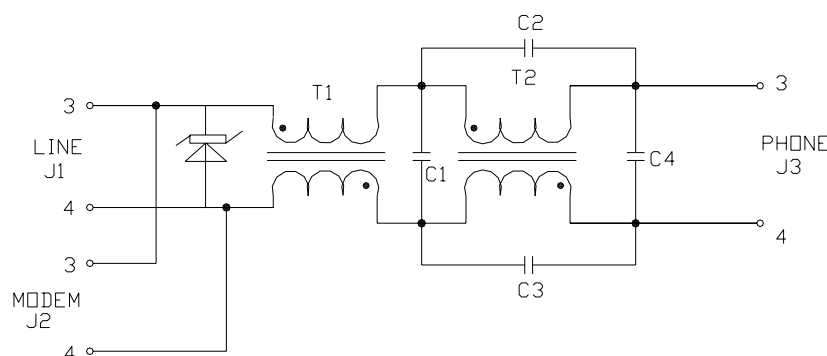

Features

- POTS -3dB, cut off frequency: 7/8kHz
- POTS pass ripple loss: (20Hz to 4kHz)+/-0.5dB
- Attenuation: 30-300kHz>-65dB, 30-1104kHz>-55dB
- DC Resistance each line: 12.5 Ohms, Max.
- Insertion loss (200Hz to 4kHz): -0.5dB Max.
- Return loss: 300-500Hz>-16dB, 500-2000Hz>-18dB, 2000-2400Hz>-18dB
- Longitudinal balance (CMRR):200Hz-1kHz): -58dB Min. 3kHz: -53dB Min.
- POTS loop current: 100mA DC
- Envelope delay distortion (0.2 to 4.0kHz): 100usec. Max.
- Impedance (300Hz to 3.4kHz): 600 Ohms
- Hi-Pot test: Tip to Ring, DC 250V/1mA 2 Sec.
- Built in lightning arrestor ,with CE certificate, and RoHS compliance

Part No.: WT- 01E / Model No.: SP- 202A
Mechanical

Schematic

For More Information :